

ERICO® CADWELD®

Bus to Horizontal Steel, Tap Flat Style CG

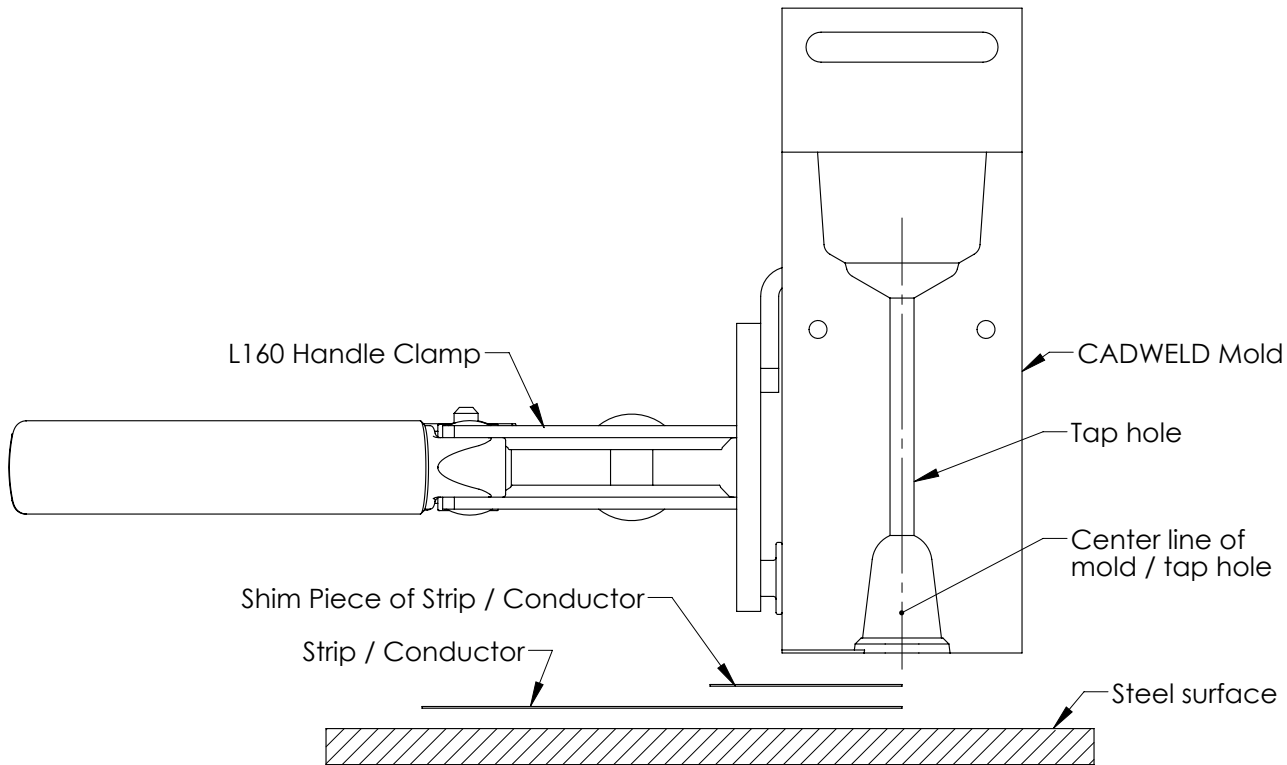
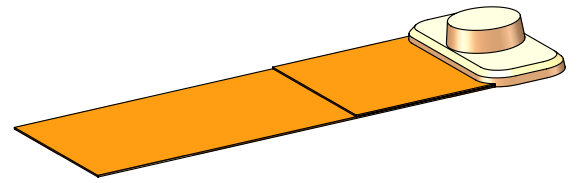

Prior to making a connection, read and follow the full instruction sheet (IPP & IPRNS) shipped with CADWELD mold and special instructions below.

1. From existing conductor stock, cut a 2 inch piece to sandwich in the mold as shown as a shim piece.
2. Material must be flat to keep from springing the mold.
3. The conductor ends should be centered under tap hole.
4. Lock mold halves with L160 Handle Clamp, making sure there are no gaps. Secure mold to steel surface.
5. Follow standard welding instructions.

WARNING:

1. ERICO products shall be installed and used only as indicated in ERICO product instruction sheets and training materials. Instruction sheets are available at www.erico.com and from your ERICO customer service representative.
2. ERICO products must never be used for a purpose other than the purpose for which they were designed or in a manner that exceeds specified load ratings.
3. All instructions must be completely followed to ensure proper and safe installation and performance.
4. Improper installation, misuse, misapplication or other failure to completely follow ERICO's instructions and warnings may cause product malfunction, property damage, serious bodily injury and death.

SAFETY INSTRUCTIONS:

All governing codes and regulations and those required by the job site must be observed. Always use appropriate safety equipment such as eye protection, hard hat, and gloves as appropriate to the application.



CADDY, CADWELD, CRITEC, ERICO, ERIFLEX, ERITECH, and LENTON are registered trademarks of ERICO International Corporation.